

ADVANCED ARCHITECTURES

SIMD CLASS AND VECTOR ARCHITECTURES

Annalisa Massini

2025-2026

Lectures 13 - 14

Computer Architecture - A Quantitative Approach, Fifth Edition

J.L. Hennessy, D. A. Patterson

- Chapter 4 - Data-Level Parallelism in Vector, SIMD, and GPU Architectures

Parallel Computer Architecture: A Hardware/Software Approach

D.E. Culler, J. P. Singh, A. Gupta

- Chapter 1.3.5 Data Parallel Processing

Introduction to High Performance Computing for Scientists and Engineers *G. Hager G. Wellein*

- Chapter 1.6 Vector processors

SIMD ARCHITECTURES

SIMD architectures

- SIMD (Single Instruction Multiple Data) architectures are effective for applications having a significant data-level parallelism (DLP):
 - matrix-oriented computations of scientific computing
 - media oriented image
 - sound processing
- Since a single instruction can launch many data operations, **SIMD is potentially more energy efficient than MIMD** (Multiple Instruction Multiple Data), which needs to fetch and execute one instruction per data operation

SIMD architectures

- Perhaps the biggest advantage of SIMD versus MIMD is that the **programmer continues to think sequentially** yet achieves parallel speedup by having parallel data operations
- For problems with lots of data parallelism, all SIMD variations share the advantage of being easier for the programmer than classic parallel MIMD programming
- We will consider two variations of SIMD:
 - **vector architectures (developed for more than 40 year)**
 - **graphics processing units (GPUs)**
- *We do not consider SIMD extension of instruction set, which is common in architectures that support multimedia applications*

SIMD architectures

- ***Vector architectures*** means essentially **pipelined execution** of many data operations
- ***Vector architectures*** are easier to understand and compile than other SIMD variations, but they were considered too expensive for microprocessors until recently
- Part of that expense was in ***transistors*** and part was in the cost of sufficient ***DRAM bandwidth***, given the widespread dependence on caches to meet memory performance demands on conventional microprocessors

SIMD architectures

- **GPUs** represent a variation on SIMD offering **higher potential performance** than is found in traditional multicore computers today
- **GPUs** share features with vector architectures, but they **have their own distinguishing characteristics**, in part due to the context in which they evolved
- The GPU and its graphics memory are associated with a system processor and system memory, and the architecture is referred to as *heterogeneous*, and indeed, the system processor is called *host* and the GPU is called *device*

SIMD architectures

- For problems with lots of data parallelism, all SIMD variations share the **advantage of being easier** for the programmer **than classic parallel MIMD** programming
- In 2011, Hennessy and Patterson wrote in their book that:
*“Over the next decade the potential speedup from SIMD parallelism is twice that of MIMD parallelism. Hence, it’s at least as **important to understand SIMD parallelism** as MIMD parallelism, although the latter has received much more fanfare recently.”*
- The goal is to understand vector architectures, as well as the similarities and differences between vector architectures and GPUs

VECTOR PROCESSORS: HISTORY

Vector processors

- Development of **vector processors** was in the mid '70s
- **Vector processors** follow the SIMD paradigm which demands that a single machine instruction is automatically applied to a – **presumably large** – number of arguments of the same type, i.e., a **vector**, rather than individual scalar data
- Vector operations permit more **parallelism** to be obtained within a **single thread of control**
- Vector supercomputers were implemented in *very fast, expensive, high power circuit technologies*

Vector processors

- In ***vector processors***, a **scalar processor** is integrated with a **collection of function units** that operate on ***vectors of data*** out of one memory in a **pipelined fashion**
- The ability to **operate on vectors** anywhere in memory:
 - eliminates the need to map application data structures onto a **rigid interconnection structure**
 - greatly simplifies the problem of getting **data aligned** so that local operations can be performed
- Most modern cache-based microprocessors have adopted some of vector architecture ideas in the form of ***SIMD instruction set extensions***

Vector processors

- The first vector processor was the **CDC Star 100** designed, manufactured, and marketed by Control Data Corporation (CDC) in 1974
 - The name **STAR** comes from the words *STrings* of binary digits that made up *ARrays*, referring to the vector concept
 - The **100** came from *100 million floating point operations per second (100 MFLOPS)*, the speed at which the machine was designed to operate
- The STAR had a **64-bit architecture**, consisting of **195 instructions** and its main innovation was the inclusion of **65 vector instructions** for vector processing

Vector processors

- The **vector operations** provided in the instruction set combined **two source vectors from memory** and produced a **result vector** in memory
- The machine only operated at *full speed if the vectors were contiguous*
- A large fraction of the execution time was spent simply transposing matrices

CDC STAR 100

- CDC's approach in the **Star** architecture used what is today known as a *memory-memory architecture*
- This is referred to the way the machine gathered data
 - It set up its pipeline to **read from** and **write to memory directly**
 - This allowed the Star to use **vectors of any length** making it highly flexible
- **BUT**, as a **drawback**:
 - The **pipeline had to be very long** in order to allow it to have enough instructions in flight to make up for the slow memory

CDC STAR 100

Other drawbacks

- The machine incurred a high cost when **switching from processing vectors** to performing operations on individual randomly located operands - **scalar operations**
- The **low scalar performance** of the machine meant that after the switch had taken place and the machine was running scalar instructions, the performance was quite poor

Cray-1

- A dramatic change in 1976 with the introduction of the **Cray-1** designed, manufactured and marketed by Cray Research in 1976
- **Seymour Cray** worked at CDC from 1968 to 1972, on CDC 6600, 7600 and 8600, then decided to leave CDC for the financial difficulties in CDC due to the STAR project
- He started the Cray research with the idea of designing a new supercomputer
- Cray was able to look at the failure of the STAR and learn from it
- The over 100 Cray-1s sold, makes it one of the **most successful supercomputers in history**

Cray-1

- The **Cray-1** was the first supercomputer to successfully implement the vector processor design
- The concept of a **load-store architecture** employed in the CDC architectures is extended to apply to vectors (then rediscovered in modern RISC machines)
- Cray decided that in addition to fast vector processing, his design would also require:
 - **Excellent all-around scalar performance** → when the machine switched modes, it would still provide superior performance
 - Also, the workloads could be dramatically improved in most cases through the **use of registers**

Cray-1

- **Registers** are significantly more expensive in terms of circuitry, so only a **limited number** could be provided
- Cray's design has less flexibility in terms of vector sizes
 - Instead of reading any sized vector several times as in the STAR, the **Cray-1 reads only a portion of the vector** at a time, but it could then run several operations on that data prior to writing the results back to memory
 - Vectors in memory, of any fixed stride, were transferred to or from contiguous vector registers by **vector load and store instructions**

Cray-1

- The vector system of the new design had its own separate **pipeline**
- **Arithmetic** was performed on the **vector registers**
- The **multiplication** and **addition** units were implemented as separate hardware, so the results of one could be **internally pipelined into the next**
- The use of a very **fast scalar processor** (operating at the unprecedented rate of 80 MHz) tightly **integrated with the vector operations** utilizing a large semiconductor memory determined the beginning of supercomputing

Cray-1

- Cray-1 was the first Cray design to use **integrated circuits** (ICs)
 - ICs were mounted on large **five-layer printed circuit boards**, with up to 144 ICs per board
 - Boards were mounted **back-to-back** for **cooling** and placed in **24 racks** (of size 28-inch-high - 71 cm) containing 72 double-boards
 - The typical module (distinct processing unit) required one or two boards
- In all, the machine contained **1662 modules in 113 varieties**

Cray-1

- The high-performance circuitry generated **considerable heat** and much effort on the design of the **refrigeration system**
- Each circuit board was **paired** with a second, placed back-to-back with a sheet of copper between them, and **liquid Freon** running in stainless steel pipes was used for the cooling unit below the machine
- In order to bring **maximum speed** out of the machine, the entire chassis was bent into a large **C-shape**
- Speed-dependent portions of the system were placed on the *inside edge* of the chassis, where the **wire-lengths were shorter**

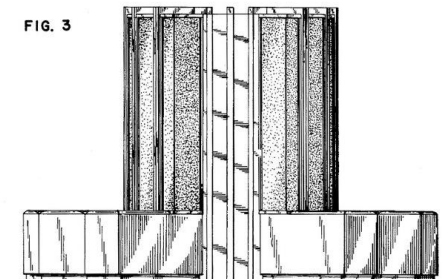
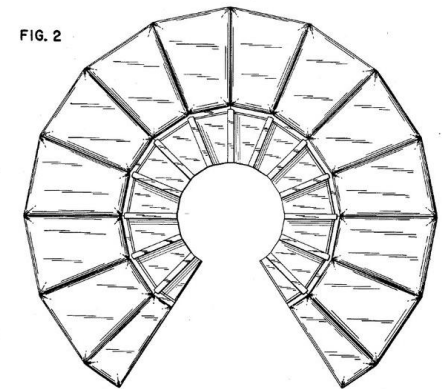

Cray 1

Over the next twenty years
Cray Research led the
supercomputing market by:

- **increasing** the **bandwidth**
for vector memory
transfers
- **increasing** the number of
processors, the number
of **vector pipelines**, and
the **length of the vector**
registers



Cray 1

- Memory was spread across 16 **interleaved memory banks**, each with a 50 ns cycle time, allowing up to four words to be read per cycle
- The main **register set** consisted of:
 - 8 64-bit **scalar** (S) registers
 - 8 24-bit **address** (A) registers
 - 8 64-element by 64-bit **vector registers** (V)
 - A **vector length** (VL) register
 - A **vector mask** (VM) register
 - A 64-bit real-time clock register
 - 4 64-bit instruction buffers that held sixty-four 16-bit instructions

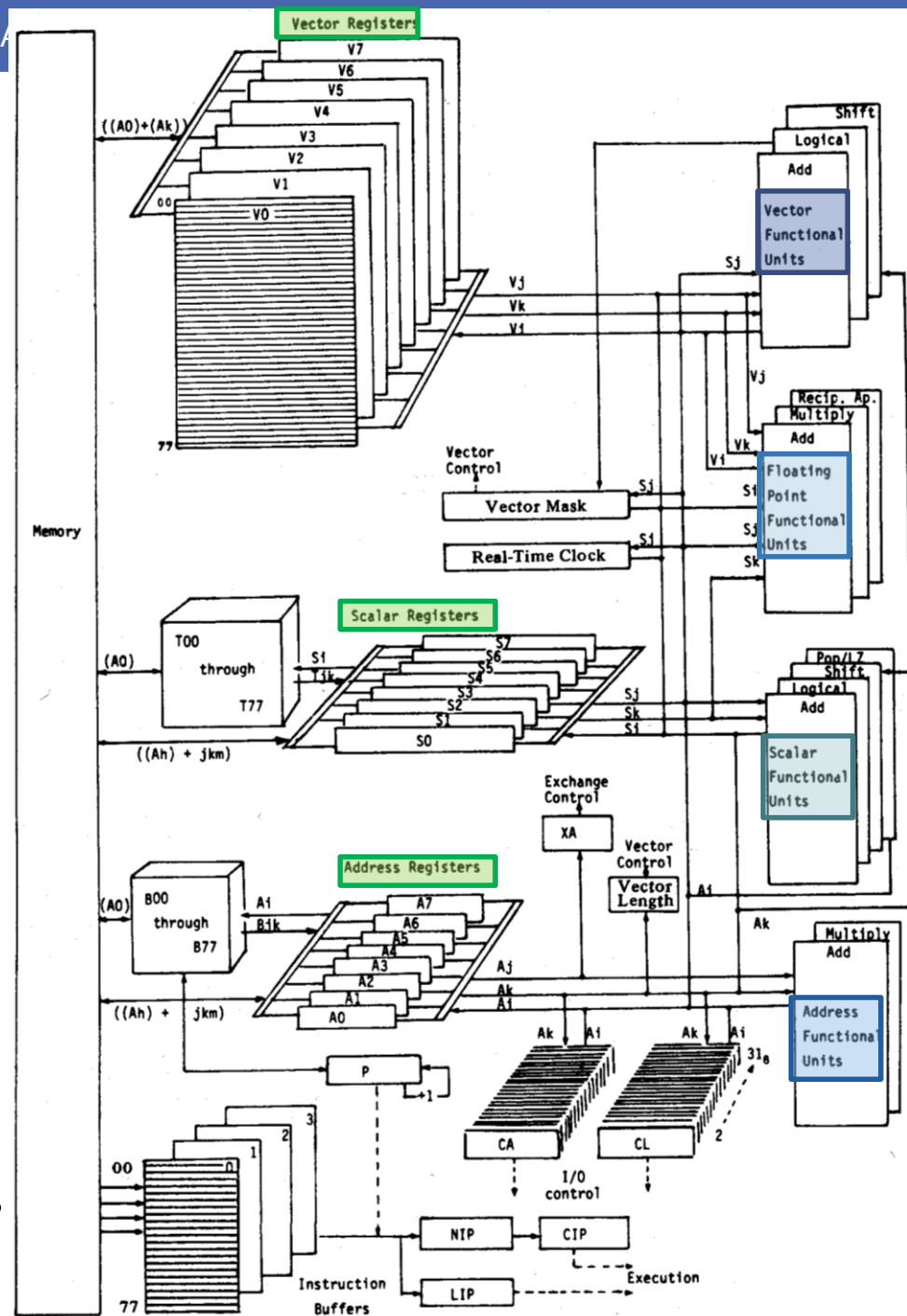

VECTOR ARCHITECTURES

Computer Architecture - A Quantitative Approach, Fifth Edition
Hennessy Patterson

Chapter 4 - Data-Level Parallelism in Vector, SIMD, and GPU Architectures
Section 4.2 - Vector Architecture

Vector Architectures

- Vector processors were successfully commercialized long before instruction level parallel machines and take an **alternative approach to controlling multiple functional units with deep pipelines**
- Vector processors provide **high-level operations** that work **on vectors linear arrays of numbers**
- **Example** A typical vector operation might add two 64-element, floating-point vectors to obtain a single 64-element vector result
- The **vector instruction** is equivalent to an **entire loop**, with each iteration computing one of the N elements of the result, updating the indices, and branching back to the beginning

Vector Architectures

Vector instructions have several important characteristics:

1. A single vector instruction is equivalent to executing a loop:
 - **Each instruction** represents **tens or hundreds of operations**
 - So, the **instruction fetch and decode** bandwidth needed to keep multiple deeply pipelined functional units busy is **dramatically reduced**

Vector Architectures

Vector instructions have several important characteristics:

2. By using a vector instruction
 - the compiler or programmer indicates that the computation of **each result in the vector is independent** of the computation of other results in the same vector
 - So **hardware does not have to check for data hazards** within a vector instruction
 - The elements in the vector can be computed using an **array of parallel functional units**, or a **single very deeply pipelined functional unit**, or any intermediate configuration of parallel and pipelined functional units

Vector Architectures

Vector instructions have several important characteristics (cont.):

3. Hardware need only check for **data hazards** between two vector instructions **once per vector operand**, not once for every element within the vectors
 - Then the dependency **checking logic** for two vector instructions is approximately the same as that for two scalar instructions, but many more elemental operations can be in flight at the same cost

Vector Architectures

Vector instructions have several important characteristics (cont.):

4. Vector instructions that **access memory** have a known access pattern
 - If the vector's elements are all adjacent, then **fetching the vector** from a set of heavily interleaved memory banks works very well
 - The **high latency of initiating a main memory** access versus accessing a cache **is amortized**, because a single access is initiated for the entire vector rather than to a single word
 - The cost of the latency to main memory is seen only once for the entire vector, rather than once for each word of the vector

Vector Architectures

- Vector processors **pipeline and parallelize** the operations on the individual elements of a vector
 - The operations include not only the **arithmetic operations** (multiplication, addition, and so on), but also **memory accesses** and effective **address calculations**
 - In addition, most high-end vector processors allow **multiple vector instructions to be in progress at the same time**, creating further parallelism among the operations on different vectors
- Vector processors are particularly useful for large scientific and engineering applications (e.g., car crash simulations, weather forecasting), for which a typical job might take dozens of hours of supercomputer time running over multigigabyte data sets

Vector Architectures

- A vector processor typically consists of an **ordinary pipelined scalar unit** plus a **vector unit**
- All functional units within the vector unit have a latency of several clock cycles
- This allows a **shorter clock cycle time** and is compatible with long-running vector operations that can be **deeply pipelined** without generating hazards
- Most vector processors allow the vectors to be dealt with as **floating-point numbers**, as **integers**, or as **logical data**
- The scalar unit is basically no different from the type of advanced pipelined CPU

Vector Architectures

- Basic idea:
 - **Read sets of data** elements scattered about memory
 - Place them into **vector registers**
 - **Operate** on those registers
 - **Disperse the results** back into memory
- There are two primary types of architectures for vector processors: **vector-register processors** and **memory-memory vector processors** (that have not been successful)
- In a vector-register processor, all vector operation – except load and store – are among the vector registers
- Since *vector loads and stores are deeply pipelined*, the program pays the long *memory latency only once* per vector load or store versus once per element, thus **amortizing the latency**

VMIPS

Computer Architecture - A Quantitative Approach, Fifth Edition
Hennessy Patterson

Chapter 4 - Data-Level Parallelism in Vector, SIMD, and GPU Architectures
Section 4.2 - Vector Architecture

VMIPS

- We now consider a vector processor as an example
- We will call this instruction set architecture **VMIPS**
 - **Its scalar portion is MIPS**
 - **Its vector portion is the logical vector extension of MIPS**
- It is loosely based on Cray-1

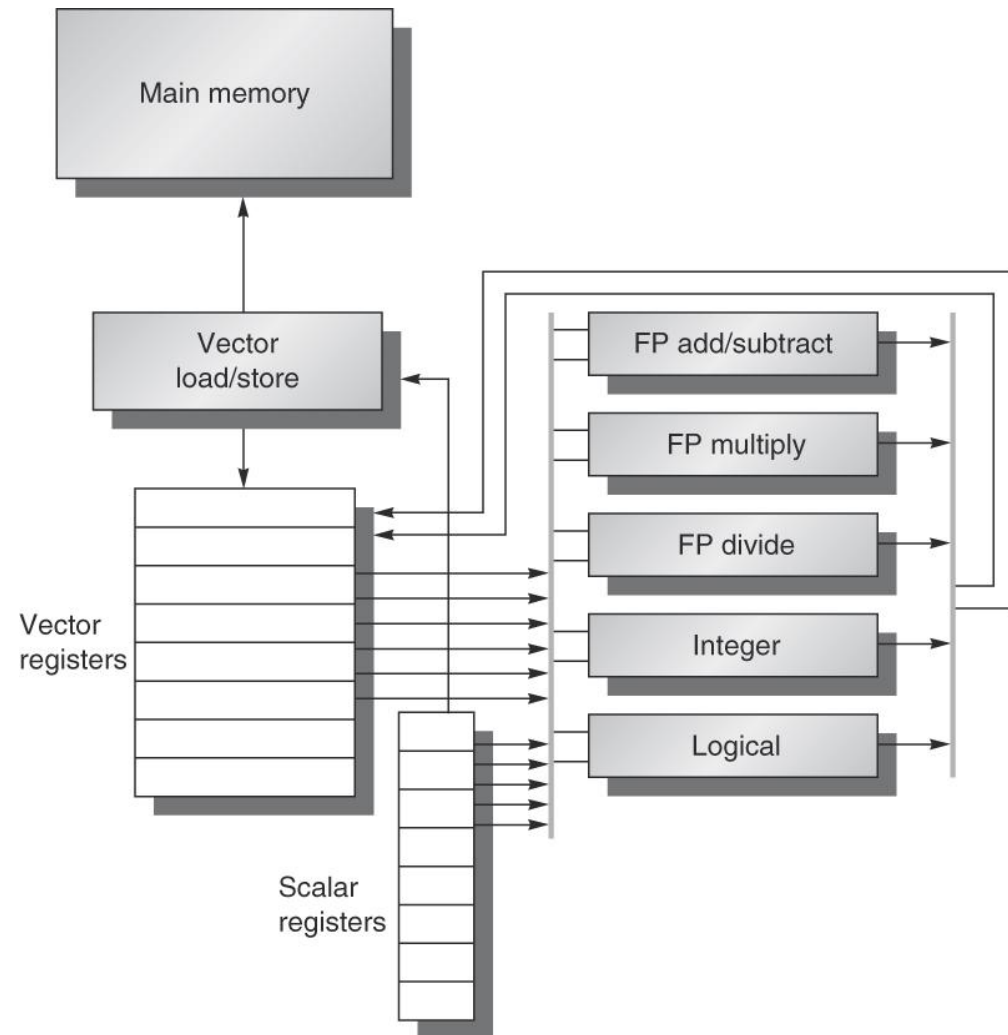

VMIPS

Primary components of VMIPS

- **Vector registers**
 - Each vector register is a fixed-length bank holding a single vector
 - VMIPS has **eight vector registers**
 - Each vector register holds a 64-element, 64 bits/element vector
 - Register file has up to 16 read ports and 8 write ports connected to the functional unit inputs or outputs by a pair of *crossbars*

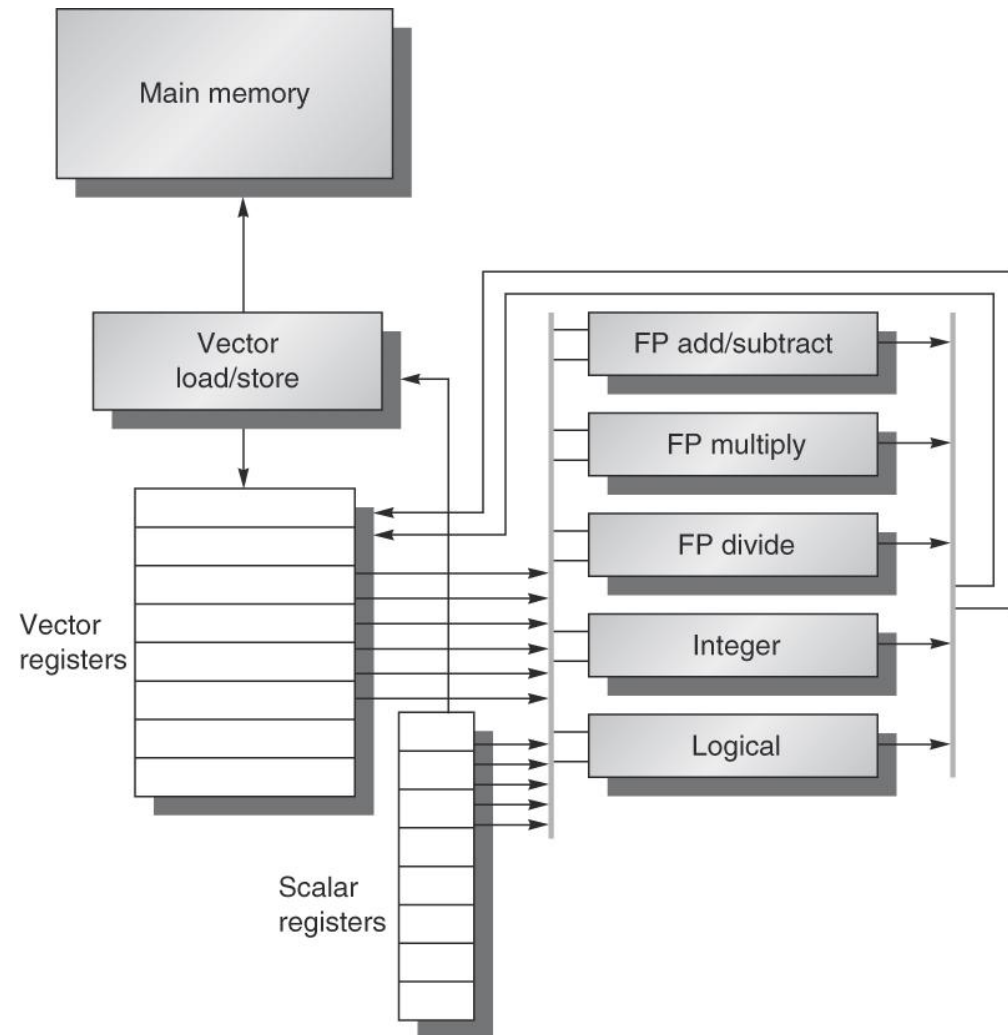

VMIPS

Primary components of VMIPS

- **Vector functional units**
 - Each unit is **fully pipelined** and can start a new operation on every clock cycle
 - A **control unit detects hazards**, for the functional units (structural hazards) and for register accesses (data hazards)
 - Depending on the vector processor, **scalar operations** either use the vector functional units or use a dedicated set

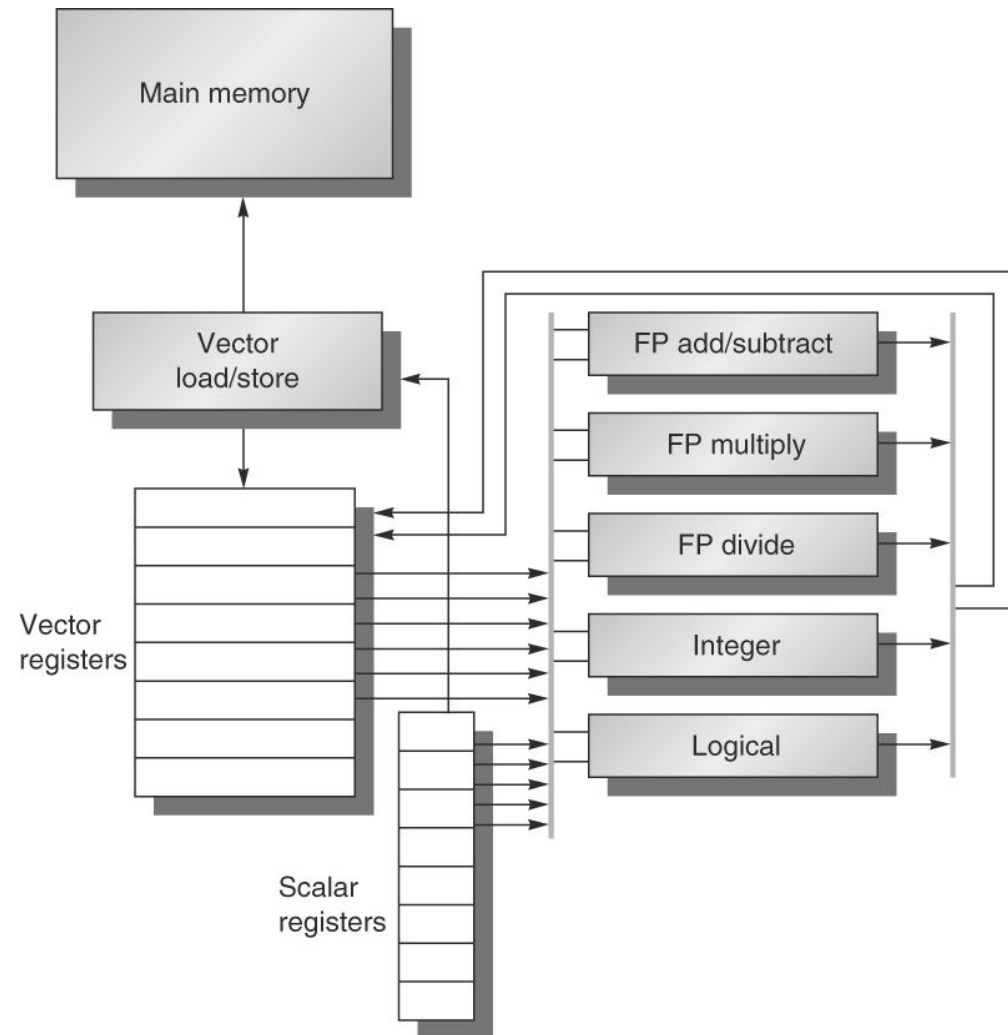

VMIPS

Primary components of VMIPS

- **Vector load-store unit**
 - vector memory unit that loads or stores a vector to or from memory
 - Fully pipelined
 - One word per clock cycle after initial latency
- **Scalar registers**
 - Scalar registers can provide data as input to the vector functional units, as well as compute addresses to pass to the vector load-store unit
 - 32 general-purpose registers
 - 32 floating-point registers

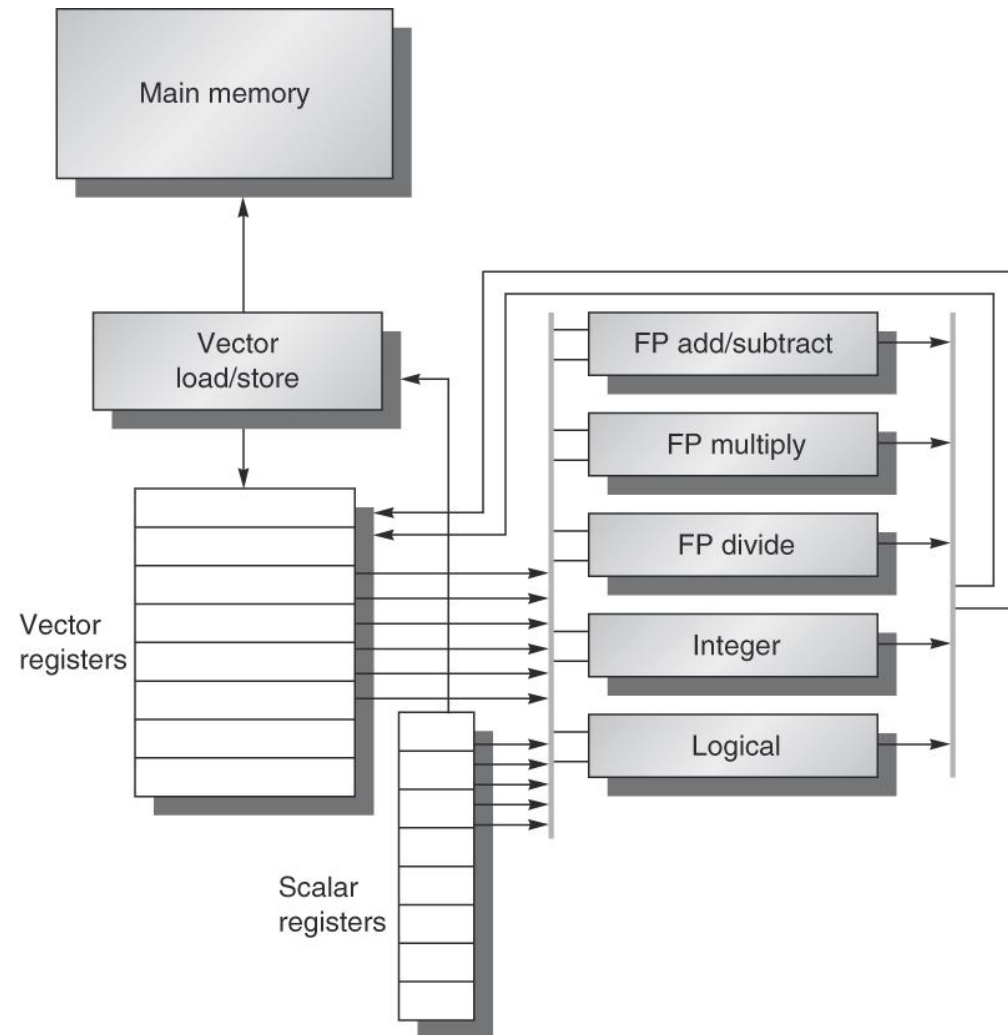

VMIPS

VMIPS in summary

- scalar architecture just like MIPS
- **eight** 64-element vector
- all the functional units are **vector functional units**
- vector units for logical and integer operations
- the vector and scalar registers have a significant number of read and write ports to allow multiple simultaneous vector operations
- a set of crossbar switches (thick gray lines) connects these ports to the inputs and outputs of the vector functional units

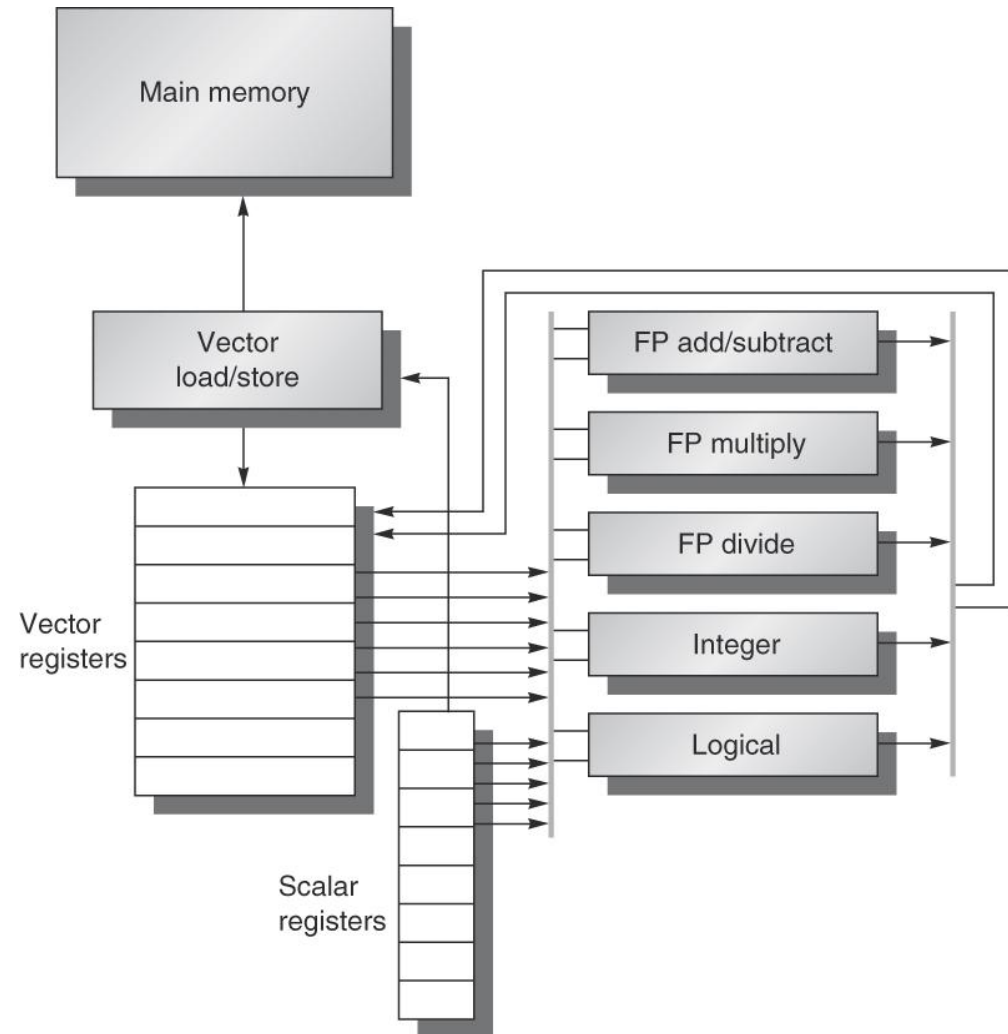

Vector Architectures

- In VMIPS, **vector operations** use the same names as MIPS operations, but with the letter **V** appended
 - **ADDV.D** is an add of two double-precision vectors
- The vector instructions take as their input:
 - either a pair of vector registers (ADDV.D)
 - or a vector register and a scalar register, designated by appending **VS** (ADDVS.D)
- Most vector operations have a vector destination register, although a few produce a scalar value, stored to a scalar register

Vector Architectures

- The names **LV and SV** denote *vector load* and *vector store*, and they load or store an entire vector of double-precision data
 - One operand is the vector register to be loaded or stored, the other operand, which is a MIPS general-purpose register, is the starting address of the vector in memory
- In addition to the vector registers, we need two additional special-purpose registers: the **vector-length VL** and **vector-mask VM** registers

VMIPS Instructions

Instruction	Operands	Function
ADDVV.D	V1, V2, V3	Add elements of V2 and V3, then put each result in V1.
ADDVS.D	V1, V2, F0	Add F0 to each element of V2, then put each result in V1.
SUBVV.D	V1, V2, V3	Subtract elements of V3 from V2, then put each result in V1.
SUBVS.D	V1, V2, F0	Subtract F0 from elements of V2, then put each result in V1.
SUBSV.D	V1, F0, V2	Subtract elements of V2 from F0, then put each result in V1.
MULVV.D	V1, V2, V3	Multiply elements of V2 and V3, then put each result in V1.
MULVS.D	V1, V2, F0	Multiply each element of V2 by F0, then put each result in V1.
DIVVV.D	V1, V2, V3	Divide elements of V2 by V3, then put each result in V1.
DIVVS.D	V1, V2, F0	Divide elements of V2 by F0, then put each result in V1.
DIVSV.D	V1, F0, V2	Divide F0 by elements of V2, then put each result in V1.
LV	V1, R1	Load vector register V1 from memory starting at address R1.
SV	R1, V1	Store vector register V1 into memory starting at address R1.
LVWS	V1, (R1, R2)	Load V1 from address at R1 with stride in R2 (i.e., $R1 + i \times R2$).
SVWS	(R1, R2), V1	Store V1 to address at R1 with stride in R2 (i.e., $R1 + i \times R2$).
LVI	V1, (R1+V2)	Load V1 with vector whose elements are at $R1 + V2(i)$ (i.e., V2 is an index).
SVI	(R1+V2), V1	Store V1 to vector whose elements are at $R1 + V2(i)$ (i.e., V2 is an index).
CVI	V1, R1	Create an index vector by storing the values $0, 1 \times R1, 2 \times R1, \dots, 63 \times R1$ into V1.
S--VV.D	V1, V2	Compare the elements (EQ, NE, GT, LT, GE, LE) in V1 and V2. If condition is true, put a 1 in the corresponding bit vector; otherwise put 0. Put resulting bit vector in vector-mask register (VM). The instruction S--VS.D performs the same compare but using a scalar value as one operand.
S--VS.D	V1, F0	
POP	R1, VM	Count the 1s in vector-mask register VM and store count in R1.
CVM		Set the vector-mask register to all 1s.
MTC1	VLR, R1	Move contents of R1 to vector-length register VL.
MFC1	R1, VLR	Move the contents of vector-length register VL to R1.
MVTM	VM, F0	Move contents of F0 to vector-mask register VM.
MVFM	F0, VM	Move contents of vector-mask register VM to F0.

DAXPY in MIPS Instructions

Example: DAXPY (double precision $a * X + Y$)

- MIPS code requires the execution of almost **600 MIPS** instructions

	L.D	F0, a;	load scalar a
	DADDIU	R4, Rx, #512;	last address to load
Loop:	L.D	F2, 0(Rx);	load X[i]
	MUL.D	F2, F2, F0;	a * X[i]
	L.D	F4, 0(Ry);	load Y[i]
	ADD.D	F4, F2, F2;	a * X[i] + Y[i]
	S.D	F4, 9(Ry);	store into Y[i]
	DADDIU	Rx, Rx, #8;	increment index to X
	DADDIU	Ry, Ry, #8;	increment index to Y
	SUBBU	R20, R4, Rx;	compute bound
	BNEZ	R20, Loop;	check if done

DAXPY in VMIPS Instructions

Example: DAXPY (double precision $a * X + Y$)

- VMIPS code requires the execution of **6 VMIPS** instructions
 - ADDVV.D adds two vectors and ADDVS.D adds vector to a scalar
 - LV/SV: vector load and vector store from address

```

L.D      F0 , a ;          load scalar a
LV       V1 , Rx ;        load vector X
MULVS.D  V2 , V1 , F0 ;   vector-scalar multiply
LV       V3 , Ry ;        load vector Y
ADDVV.D  V4 , V2 , V3 ;   add
SV       V4 , Ry ;        store the result

```

- The reduction occurs because
 - the vector operations work on 64 elements
 - the **overhead instructions** that constitute nearly half the loop on MIPS **are not present** in the VMIPS code

Vector Execution Time

- **Execution time** depends on three factors:
 - Length of operand vectors
 - Structural hazards
 - Data dependences
- We can compute *the time for a single vector instruction* given
 - The vector length
 - The *initiation rate*, rate at which a vector unit consumes new operands and produces new results
- Assuming *initiation rate* of one element per clock cycle for individual operations, we obtain that *the execution time is approximately the vector length*

Vector Execution Time - Convoy

- To discuss vector execution and vector performance, the notion of *convoy* is used
 - Set of vector instructions that could potentially execute together
- We can estimate *performance* of a section of code by counting the *number of convoys*
 - The instructions in a convoy *must not contain any structural hazards*
 - If such hazards were present, the instructions would need to be serialized and initiated in different convoys
 - To simplify, we assume that a convoy of instructions must complete execution before any other instructions (scalar or vector) can begin execution

Vector Execution Time - Convoy

- **Example** Division of the following code sequence in **convoys**, assuming a single copy of each vector functional unit

<code>LV V1,Rx;</code>	<code>load vector X</code>
<code>MULVS.D V2,V1,F0;</code>	<code>vector-scalar multiply</code>
<code>LV V3,Ry;</code>	<code>load vector Y</code>
<code>ADDV.D V4,V2,V3;</code>	<code>add</code>
<code>SV Ry,V4;</code>	<code>store the result</code>

Vector Execution Time - Convoy

- **Example** Division of the following code sequence in **convoys**, assuming a single copy of each vector functional unit

<code>LV V1,Rx;</code>	<code>load vector X</code>
<code>MULVS.D V2,V1,F0;</code>	<code>vector-scalar multiply</code>
<code>LV V3,Ry;</code>	<code>load vector Y</code>
<code>ADDV.D V4,V2,V3;</code>	<code>add</code>
<code>SV Ry,V4;</code>	<code>store the result</code>

- **Answer**
 - The first convoy is occupied by the first LV instruction
 - The MULVS.D is dependent on the first LV, cannot be in the same convoy. The second LV instruction can be in the same convoy as the MULVS.D
 - The ADDV.D is dependent on the second LV, so it must be in a third convoy
 - Finally the SV depends on the ADDV.D, so it must go in a following convoy
 - The **four convoys** are: - 1. LV - 2. MULVS.D & LV - 3. ADDV.D - 4. SV

Vector Execution Time - Chaining

- Sequences with *read-after-write* dependency hazards can be in the same convoy via **chaining**
- **Chaining**
 - Allows a **vector operation** to start **as soon as** the individual elements of its vector **source operand become available**
 - The results from the first functional unit *in the chain* are **forwarded** to the second functional unit
 - Early implementations of chaining worked just like forwarding in scalar pipelining
 - Recent implementations use **flexible chaining**, which allows a vector instruction to chain to any other active vector instruction, assuming we do not generate any structural hazard

Vector Execution Time - Chime

- To turn **convoys** into **execution time** we need a timing metric for estimating the performance of a vector sequence consisting of convoys
- **chime** is the *unit of time to execute one convoy*
 - A vector sequence that consists of m convoys executes in m chimes
 - For vector length of n , it requires approximately $m \times n$ clock cycles
 - The chime approximation ignores some processor-specific *overheads*, many of which are dependent on vector length
 - Measuring time in **chimes** is a better approximation for long vectors than for short ones
 - If we know the number of convoys in a vector sequence, we know the execution time in chimes

Vector Execution Time - Chime

- The most important source of overhead ignored by the chime model is vector ***start-up time***
- *Start-up time* is determined by:
 - the ***pipelining latency*** of vector functional unit, and
 - by how deep the pipeline is *for the functional unit* used
- The start-up time increases the effective time to execute a convoy to more than one chime
 - For VMIPS we assume the same pipeline depths as Cray-1
 - Floating-point add => 6 clock cycles
 - Floating-point multiply => 7 clock cycles
 - Floating-point divide => 20 clock cycles
 - Vector load => 12 clock cycles

OPTIMIZATIONS ON VECTOR ARCHITECTURES

Computer Architecture - A Quantitative Approach, Fifth Edition
Hennessy Patterson

Chapter 4 - Data-Level Parallelism in Vector, SIMD, and GPU Architectures
Section 4.2 - Vector Architecture

Optimizations

- Given these vector basics, there are several optimizations that improve the performance on vector architectures
 - *Multiple Lanes*: > 1 element per clock cycle
 - *Vector Length Registers*: Non-64 wide vectors
 - *Vector Mask Registers*: IF statements in vector code
 - *Memory Banks*: Memory system optimizations to support vector processors
 - *Stride*: Multiple dimensional matrices
 - *Scatter-Gather*: Sparse matrices
 - *Programming Vector Architectures*: Program structures affecting performance

Multiple Lanes

- The advantage of a **vector instruction set** is that it allows software to **pass a large amount of parallel work** to hardware **using only a single short instruction**
- The parallel semantics of a vector instruction allow an implementation to execute these elemental operations using:
 - a **deeply pipelined functional unit**
 - an **array of parallel functional units**
 - a **combination** of parallel and pipelined functional units

Multiple Lanes

- A **parallel vector unit** can be build by **multiple parallel *lanes***
- As with a traffic highway, we can increase the peak throughput of a vector unit by adding ***more lanes***

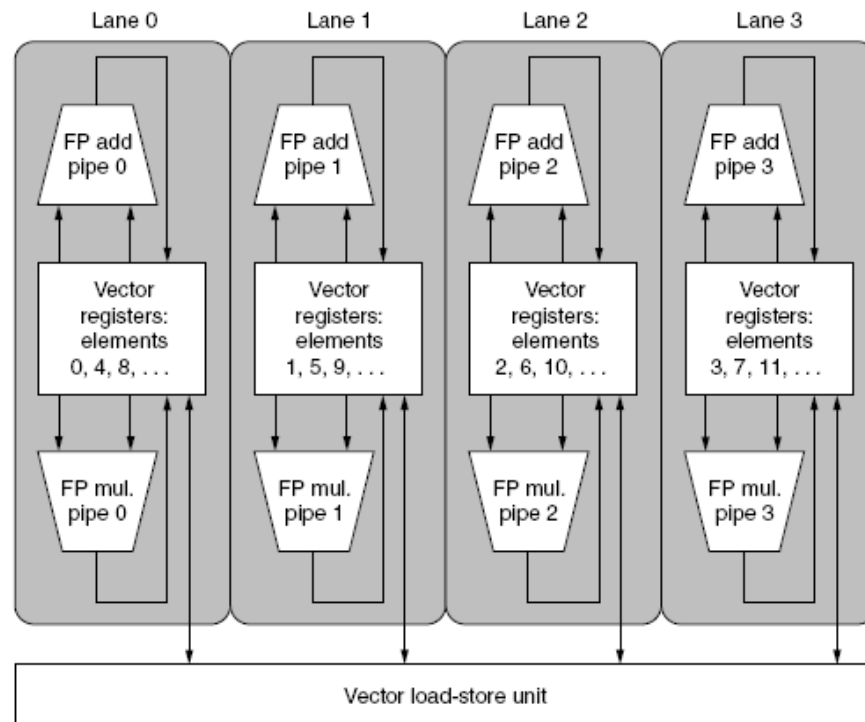

Multiple Lanes

Structure of a vector unit containing **four lanes**

- The vector register storage is divided across the lanes, with **each lane** holding **every fourth element** of each vector register
- **Three** vector functional units: **FP add**, **FP multiply**, **load-store unit**

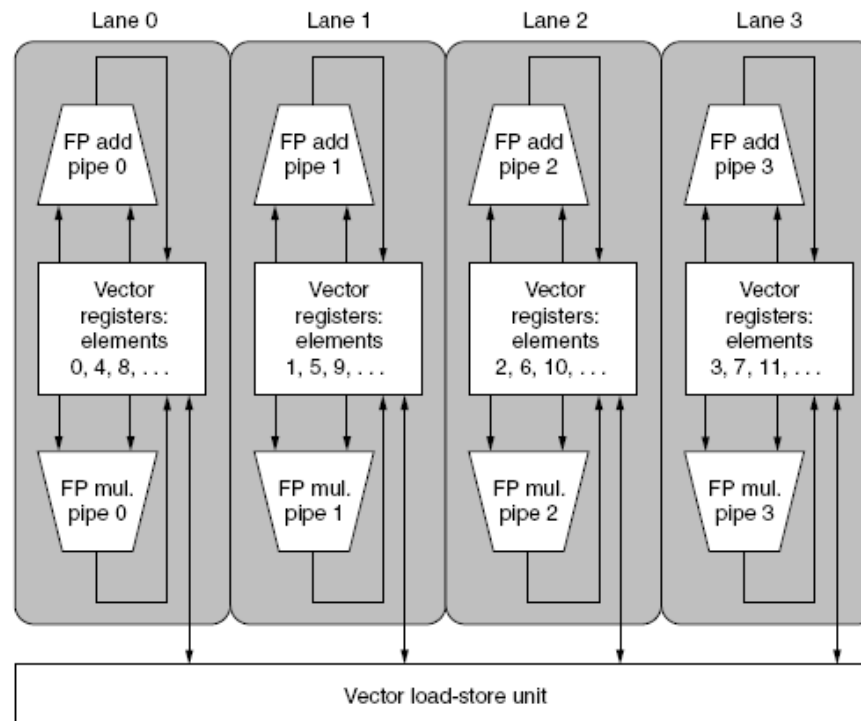

Multiple Lanes

- Figure illustrates how to improve vector performance by using **parallel pipelines** to execute a **vector add instruction**

Using multiple functional units improves the performance of a single vector add instruction

$$C = A + B$$

Figure (a) The vector processor has a **single add pipeline** and can complete **one addition per cycle**

Figure (b) The vector processor has **four add pipelines** and can complete **four additions per cycle**. The elements within a single vector add instruction are interleaved across the four pipelines. The set of elements moving through the pipelines together is an **element group**

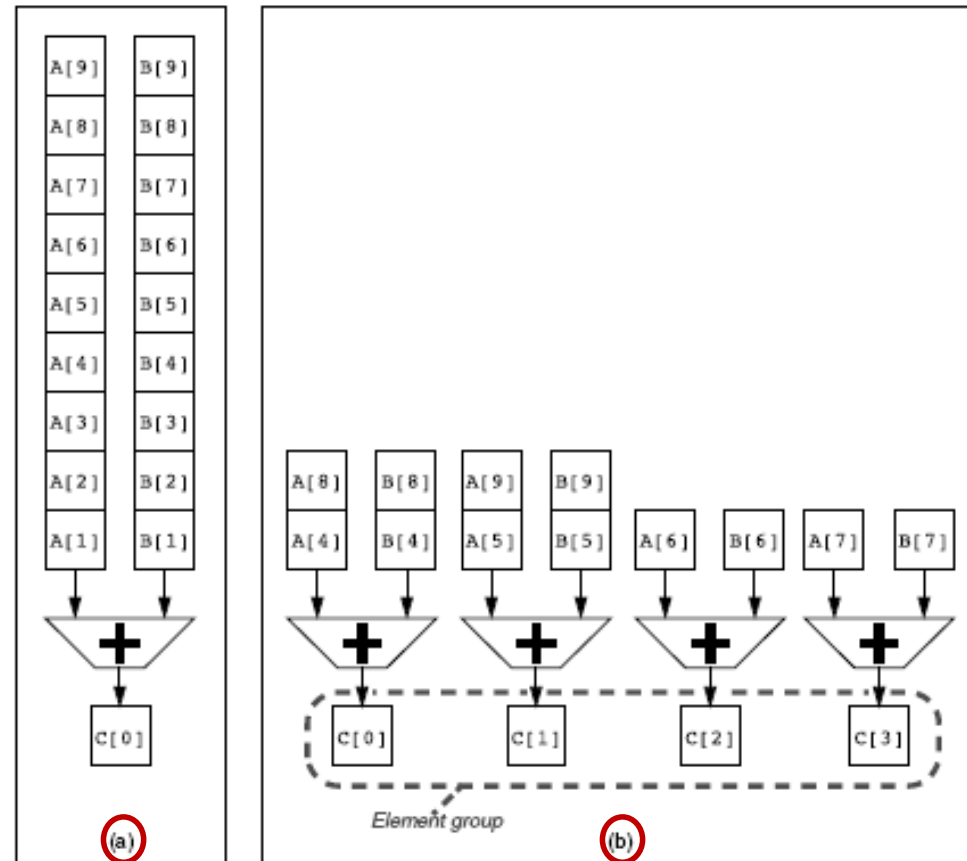

Vector Length Registers Handling Loops Not Equal to 64

- What can you do when the vector length in a program is not exactly 64?
- Real vector **length n** in a program is unlikely to match the vector length of a register, which in VMIPS is 64
- Moreover, the **vector length is not known** at **compile time**
- For example, consider the code for DAXPY:

```
for (i=0; i <n; i=i+1)
  Y[i] = a * X[i] + Y[i];
```
- The size of all the vector operations depends on n , which may **not even be known** until **run time**
- n might also be a parameter to a procedure containing the above loop and subject to change during execution

Vector Length Registers Handling Loops Not Equal to 64

- The solution is to create a ***vector-length register (VLR)*** that:
 - controls the length of any vector operation, including a vector load or store
 - **but** the value in the VLR cannot be greater than the length of the vector registers
- Then also the ***maximum vector length (MVL)*** is used
 - ***MVL determines the number*** of data elements in a vector of an architecture
 - MVL parameter means the length of vector registers can grow in later computer generations without changing the instruction set

Vector Length Registers Handling Loops Not Equal to 64

- If the value of n is not known at compile time and is greater than the MVL, a technique called **strip mining** is used
 - Generation of code such that each vector operation is done for a size less than or equal to the MVL
 - It consists in creating:
 - one loop that handles any number of iterations that is a multiple of the MVL
 - another loop that handles any **remaining iterations** and must be less than the MVL
- In practice, compilers usually create a **single strip-mined loop** that is parameterized to handle both portions by changing the length

Vector Length Registers Handling Loops Not Equal to 64

- The **strip-mined version** of the DAXPY loop in C:

```
low = 0;
VL = (n % MVL);    /*find odd-size piece using modulo op % */
for (j = 0; j <= (n/MVL); j=j+1) {    /*outer loop*/
    for (i = low; i < (low+VL); i=i+1)    /*runs for length VL*/
        Y[i] = a * X[i] + Y[i] ;    /*main operation*/
    low = low + VL;    /*start of next vector*/
    VL = MVL;    /*reset the length to max vector length*/
}
```

- The length of the first segment is $(n \% MVL)$, and all subsequent segments are of length MVL

Vector Mask Registers IF Statements in Vector Loops

- The presence of conditionals (**IF statements**) inside loops introduce **control dependences** into the loop

- Consider:

```
for (i = 0; i < 64; i=i+1)
    if (X[i] != 0)
        X[i] = X[i] - Y[i];
```

- This loop **cannot** normally **be vectorized** because of the conditional execution of the body
- **BUT** if the inner loop could be run for the **iterations for which $X[i] \neq 0$** , then the subtraction could be vectorized

Vector Mask Registers IF Statements in Vector Loops

- The solution is **vector-mask control**
- **Mask registers** provide conditional execution of vector instruction using a Boolean vector
- When the **vector-mask register is enabled**, any vector instructions operate only on the vector elements whose corresponding entries in the vector-mask register are 1

- Use vector mask register to “disable” elements (*if conversion*):

```

LV V1,Rx;           load vector X into V1
LV V2,Ry;           load vector Y
L.D F0,#0;         load FP zero into F0
SNEVS.D V1,F0;     sets VM(i) to 1 if V1(i)≠F0
SUBVV.D V1,V1,V2;  subtract under vector mask
SV Rx,V1;          store the result in X
  
```

- As a consequence, GFLOPS rate decreases

Memory Banks

Bandwidth for Vector Load/Store Units

- **Memory systems** must be designed to support **high bandwidth** for vector loads and stores
- **Spreading accesses** across multiple independent **memory banks** usually delivers the desired rate
- **Vector processors use memory banks** for the following reasons:
 - To support simultaneous accesses from **multiple loads or stores**, the memory system needs multiple banks and to be able to control the addresses to the banks independently
 - Independent bank addressing allows to load or store data words that are **not sequential**
 - In a multiple processor system with shared memory, each processor generates its own **independent stream of addresses**

Stride *Handling Multidimensional Arrays in Vector Architectures*

- The position in memory of **adjacent elements in a vector** may **not be sequential**

- Consider this code for matrix multiply in C :

```
for (i = 0; i < 100; i=i+1)
    for (j = 0; j < 100; j=j+1) {
        A[i][j] = 0.0;
        for (k = 0; k < 100; k=k+1)
            A[i][j] = A[i][j] + B[i][k] * D[k][j];
    }
```

- Must vectorize multiplication of **rows of B** with columns of D
- An array in memory is linearized in either row-major (as in C) or column-major (as in Fortran) order, then either the elements in the row or in the column **are not adjacent in memory**

Stride *Handling Multidimensional Arrays in Vector Architectures*

- The distance separating elements to be gathered into a single register is called the **stride**
 - In our example, matrix D has a stride of 100 double words (800 bytes), and matrix B has a stride of 1 double word (8 bytes)
 - For column-major order, the strides would be reversed
- A vector processor can handle strides greater than one (**non-unit strides**) *using only vector load and vector store operations with stride capability*
- This ability to access non-sequential memory locations and to reshape them into a dense structure is one of the major advantages of a vector processor

Stride *Handling Multidimensional Arrays in Vector Architectures*

Example

- 8 memory banks with a bank busy time of 6 cycles and a total memory latency of 12 cycles
- How long will it take to complete a 64-element vector load with a stride of 1? With a stride of 32?

Stride *Handling Multidimensional Arrays in Vector Architectures*

Example

- 8 memory banks with a bank busy time of 6 cycles and a total memory latency of 12 cycles
- How long will it take to complete a 64-element vector load with a stride of 1? With a stride of 32?
- **Answer**
 - **Stride of 1:** number of banks is greater than the bank busy time, so it takes $12+64 = 76$ clock cycles \rightarrow 1.2 cycle per element

Stride *Handling Multidimensional Arrays in Vector Architectures*

Example

- 8 memory banks with a bank busy time of 6 cycles and a total memory latency of 12 cycles
- How long will it take to complete a 64-element vector load with a stride of 1? With a stride of 32?

• Answer

- **Stride of 1:** number of banks is greater than the bank busy time, so it takes $12 + 64 = 76$ clock cycles \rightarrow 1.2 cycle per element
- **Stride of 32:** the worst case is when the stride value is a multiple of the number of banks, as in this case. Every access to memory will collide with the previous one. Thus, the total time will be:
 $12 + 1 + 6 * 63 = 391$ clock cycles, or 6.1 clock cycles per element

Scatter-Gather Handling Sparse Matrices

- It is important to have techniques to allow programs with **sparse matrices** to execute in vector mode
- In a sparse matrix, the elements of a vector are usually stored in some compacted form and then accessed indirectly
- Consider sparse vectors A and C , and index vectors K and M , where A and C have the same number n of non-zeros:

```
for (i = 0; i < n; i=i+1)
    A[K[i]] = A[K[i]] + C[M[i]];
```

- The primary mechanism for supporting sparse matrices is *gather-scatter operations* using index vectors
- Such operations support moving between a compressed representation and normal representation of a sparse matrix

Scatter-Gather Handling Sparse Matrices

- A **gather operation** takes *an index vector* and fetches the vector whose elements are at the addresses given *by adding a base address to the offsets given in the index vector*, generating a **dense vector in a vector register**
- After these elements are operated on in dense form, the sparse vector can be stored in expanded form by a **scatter store**, using the same index vector
- This technique allows code with sparse matrices to run in vector mode
- **Hardware support** for such operations is called **gather-scatter**
- The VMIPS instructions are LVI (load vector indexed or gather) and SVI (store vector indexed or scatter)

Scatter-Gather Handling Sparse Matrices

- **Example**

```
for (i = 0; i < n; i=i+1)
    A[K[i]] = A[K[i]] + C[M[i]];
```

- **Inner loop** with VMIPS instructions LVI and SVI
- Ra, Rc, Rk and Rm contain the starting addresses of vectors

LV V _k , R _k ;	load K
LVI Va, (Ra+V _k) ;	load A[K[]]
LV V _m , R _m ;	load M
LVI V _c , (Rc+V _m) ;	load C[M[]]
ADDVV.D Va, Va, V _c ;	add them
SVI (Ra+V _k), Va ;	store A[K[]]

Programming Vector Architectures

- **Compilers** can provide feedback to programmers
- **Programmers** can provide hints to compiler

Benchmark name	Operations executed in vector mode, compiler-optimized	Operations executed in vector mode, with programmer aid	Speedup from hint optimization
BDNA	96.1%	97.2%	1.52
MG3D	95.1%	94.5%	1.00
FLO52	91.5%	88.7%	N/A
ARC3D	91.1%	92.0%	1.01
SPEC77	90.3%	90.4%	1.07
MDG	87.7%	94.2%	1.49
TRFD	69.8%	73.7%	1.67
DYFESM	68.8%	65.6%	N/A
ADM	42.9%	59.6%	3.60
OCEAN	42.8%	91.2%	3.92
TRACK	14.4%	54.6%	2.52
SPICE	11.5%	79.9%	4.06
QCD	4.2%	75.1%	2.15

Level of vectorization among the Perfect Club benchmarks executed on the Cray Y-MP [Vajapeyam 1991]

The **first column** shows the vectorization level obtained with the **compiler without hints**

The **second column** shows the results after the codes have been improved with **hints** from a team of Cray Research **73**